



UNIT 1

PHYSICAL QUANTITIES AND MEASUREMENT

PHYSICS

Physics is a branch of science that studies the properties of matter and energy and their interaction.

MAIN BRANCHES OF PHYSICS

1. MECHANICS

This branch of physics concerns the motion of particles or bodies under the action of given forces.

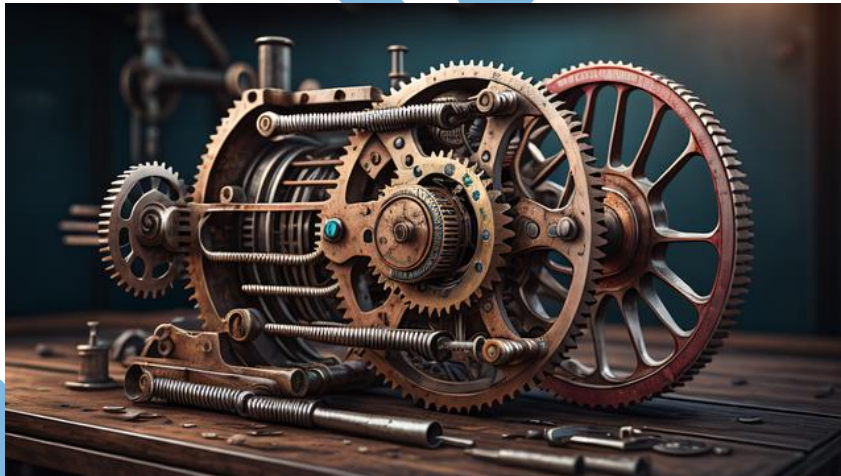

3. THERMODYNAMICS

Thermodynamics deals with heat and temperature and their relation to energy and work.



2. ELECTRICITY

it is that branch of physics concerned with physical phenomena and effects related to electric charges



3. MAGNETISM

Magnetism is the study of magnetic properties of materials

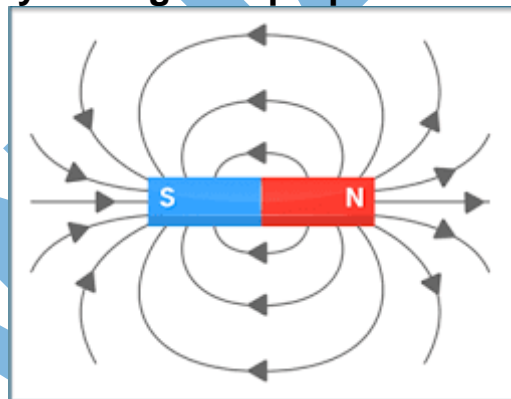

4. ATOMIC PHYSICS

It is concerned with the structure and properties of atoms as determined by the electrons outside the nucleus.



5. Nuclear Physics

It is concerned with structures, properties, and reactions between the nuclei of atoms.

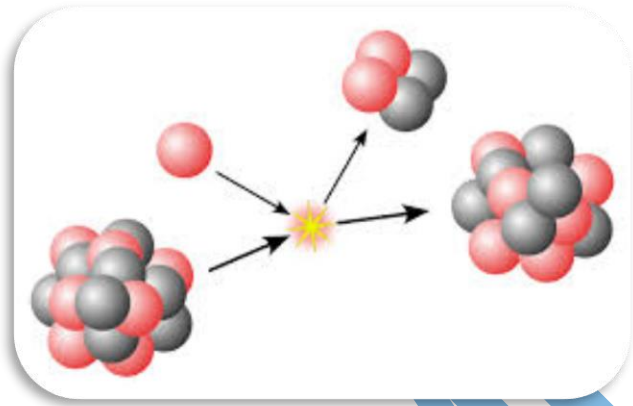

6 OPTICS

Optics studies the physical aspects of light and its properties with the help of optical instruments.



7 SOUND

is the study of p properties and applications of sound waves.



8 PARTICLE PHYSICS

Particle Physics studies the elementary constituents of matter and radiation, and the interactions between them

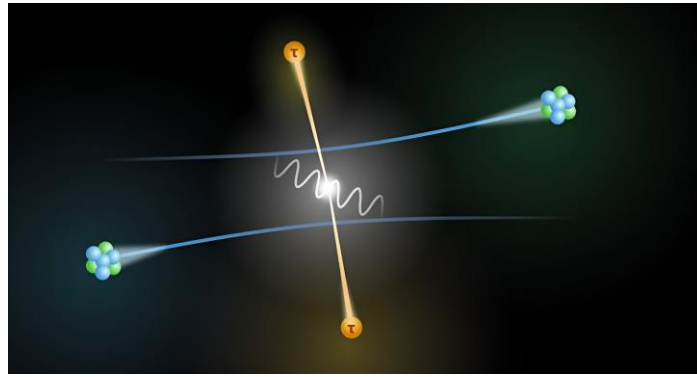

7. PLASMA PHYSICS

It is concerned with the properties of highly ionized atoms forming a mixture of bare nuclei (nuclei without electrons) and electrons called an ion plasma.

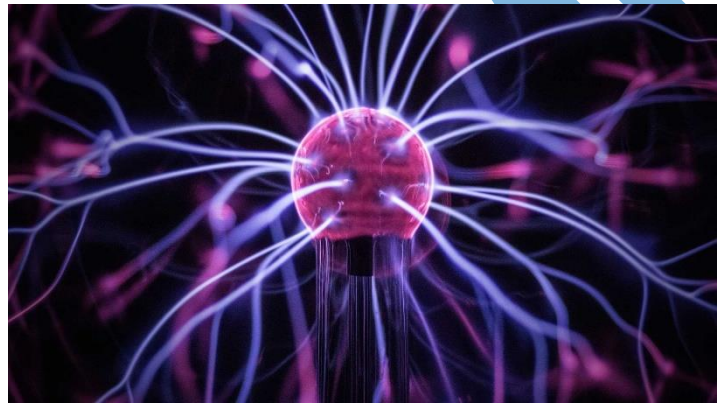

GEO PHYSICS

The study of the Earth's internal structure is known as Geo physics.

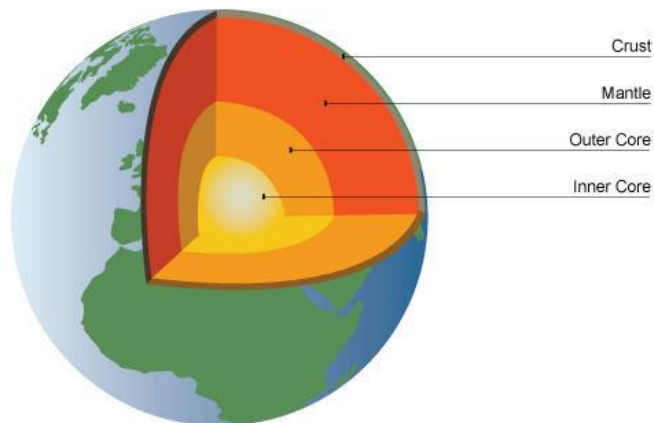

PHYSICAL QUANTITIES

A physical quantity that can be measured consists of a numerical magnitude and a unit. A measurement without a unit is meaningless.

The many physical quantities can be classified into two types; base quantities and derived quantities.

INTERNATIONAL SYSTEM OF UNITS (SI)

The international system of units is based on seven basic units from which all other units are derived. The seven basic physical quantities, their SI units, and the symbols are given in the following table.

Basic quantity	Symbol of Basic Quantity	Name of the Base SI units	Symbol of SI units
Time	T	Second	s
Length	L	Metre	m
Mass	M	Kilogram	Kg
Temperature	T, θ	Kelvin	K
Electric current	I	Ampere	A
Amount of substance	n	Mole	mol
Luminous intensity	I _v	Candela	cd

DERIVED UNIT

The units of other physical quantities derived from the fundamental units are known as derived units. These units are obtained by multiplication and division or both of fundamental units.

Quantity	Symbol of Quantity	Units	Symbol
Speed	v	Meter/second	m/s
Acceleration	a	Meter/second ²	m/s ²
Volume	V	Cubic metre	m ³
Force	F	Newton	N = (Kg. m/S ²)
Pressure	P	Pascal	P = N/m ²
Work	W	Joules	J
Momentum	P	Newton-second	Ns = (kg.m/s)

METER

The current definition of meter, which is defined as

One meter is defined to be the distance traveled by light in a vacuum in 1/299,792,458 of a second.

OR

A meter is also defined as the distance between two marks on an Iridium platinum alloy bar kept at 0°C in the International Bureau of Weights and Measures near Paris.

The multiples and submultiples units of a meter is very easily obtained by multiplying and dividing it by 10 as follows.

$$1 \text{ km} = 1000 \text{ m} = 10^3\text{m}$$

$$1\text{m} = 100 \text{ cm} = 10^2\text{cm}$$

$$1\text{m} = 1000 \text{ mm} = 10^3\text{mm}$$

INSTRUMENT USING MEASUREMENT OF LENGTH

METER RULE

A meter rule is a device which is used to measure the length of different objects. A meter rule of length 1m is equal to 100 centimeters (cm).

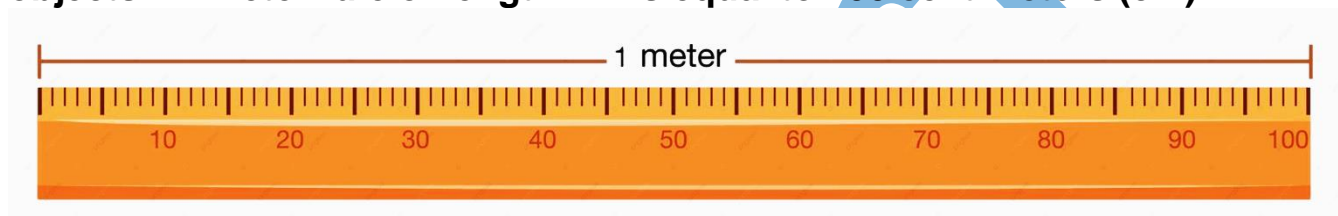

MEASUREMENT OF LENGTH OF PENCIL FROM SCALE

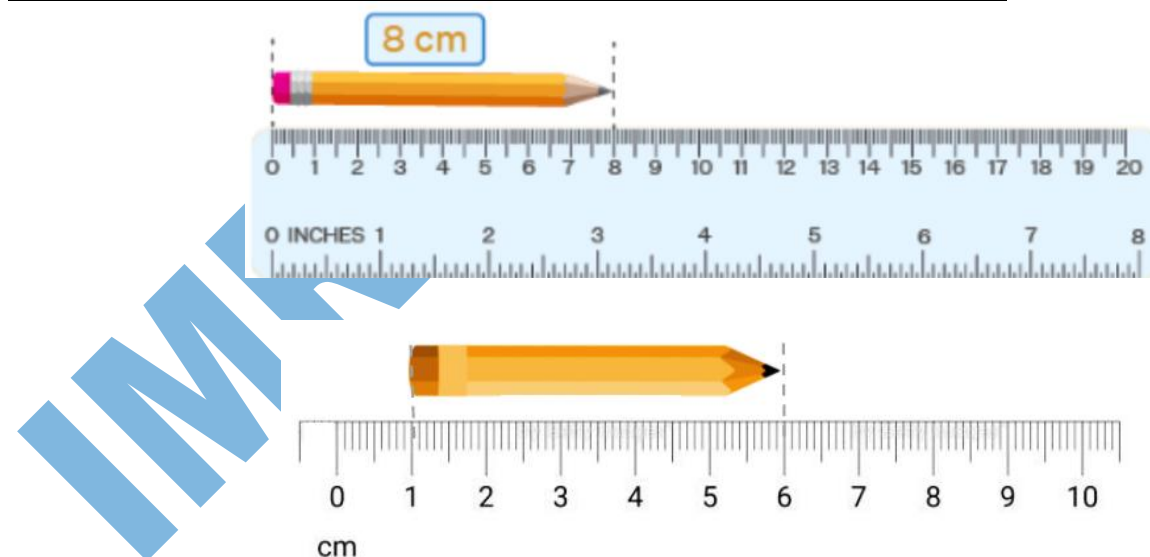

Length of pencil measured on the given scale = 6 - 1 = 5 cm

VERNIER CALIPER

The **Vernier Caliper** is a precision instrument that can be used to measure internal and external distance extremely accurate. It has both an imperial and metric scale. A Vernier caliper has main jaws that are used for measuring external diameter, as well as smaller jaws

that are used for measuring the internal diameter of objects. Some models also have a depth gauge.

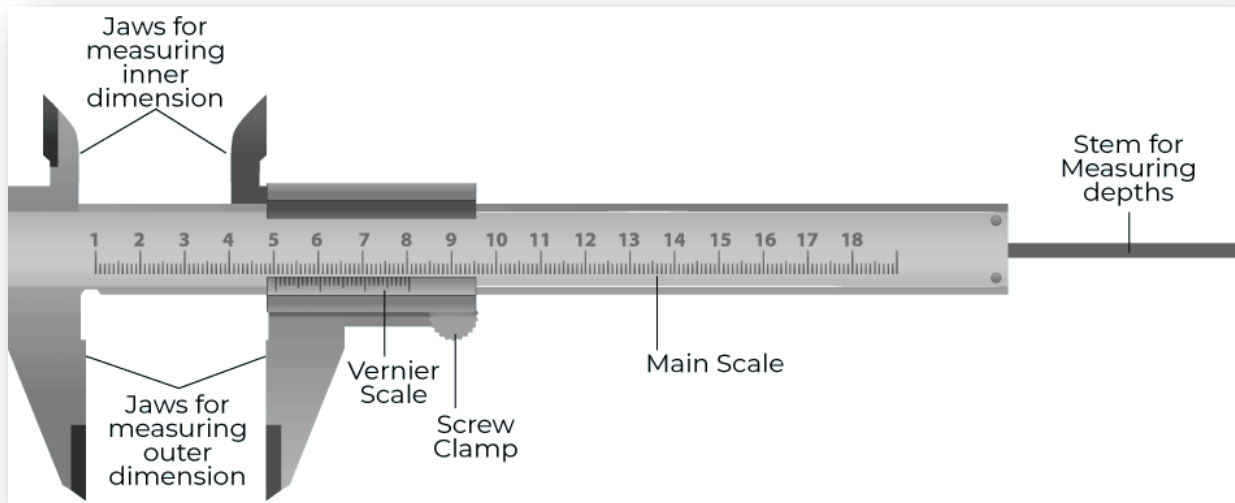

Reading a Vernier Caliper

Step 1

Place the object between the jaws of the Vernier caliper

Step 2

Note the main scale reading by counting lines before the zero line of Vernier scale

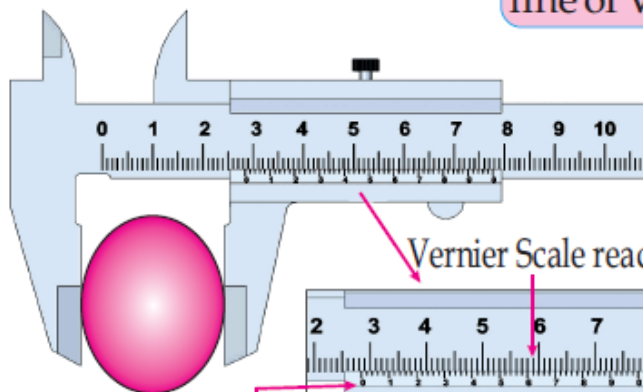

Main scale reading

$$\begin{array}{r} \text{Main scale reading} = 2.8\text{mm} \\ \text{Vernier scale reading} = 0.6\text{mm} \\ \hline \text{Total reading} = 3.4\text{mm} \end{array}$$

Step 3

Count the next line of Vernier scale after zero coinciding main scale

Step 4

Add the two reading for total

ZERO ERROR OR ZERO CORRECTION

On closing the jaws “A” and “B”, If the zero of the main scale does not coincides with the zero of the vernier scale, then the instrument has an error called zero error. There are two types of zero error in this instrument which are as follows:

1. POSITIVE ZERO ERROR

If the zero of the vernier scale is on the right of the main scale zero, then the zero error will be positive as shown in figure below:

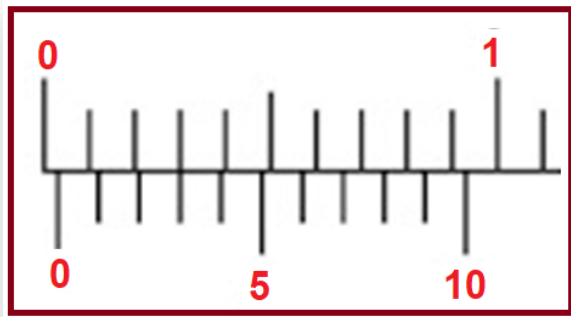

In this error to calculate it, check the vernier scale division which is exactly coincides (E) with any main scale division then

$$\text{Zero Error (Z.E)} = E \times \text{L.C.}$$

$$\text{From figure } E = 3 \text{ and L.C} = 0.01 \text{ cm}$$

$$\text{Zero Error (Z.E)} = (3 \times 0.01) = 0.03 \text{ cm}$$

2. NEGATIVE ZERO ERROR

If the zero of vernier scale is on the left of the main scale zero, then it is called negative zero error as shown in figure below:

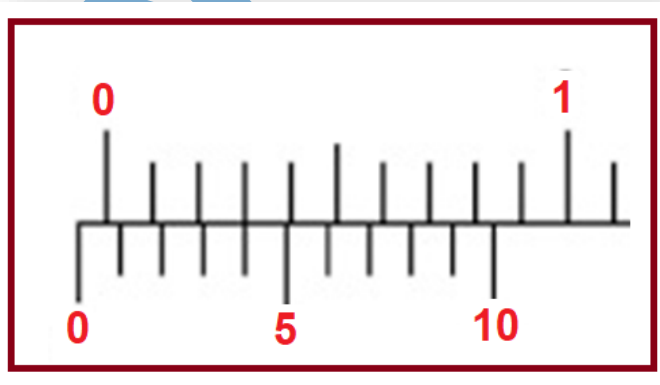

To calculate this zero error, check the vernier scale division (E) which is exactly coincides with any main scale division then

$$\text{Zero Error (Z.E)} = (10 - E) \times \text{L.C}$$

$$\text{From figure } E = 4 \text{ and L.C} = 0.01 \text{ cm}$$

$$\text{Zero Error (Z.E)} = - [(10 - 4) \times 0.01] = - 0.06 \text{ cm}$$

WORKED EXAMPLE

Q-1 What is the readings of the reading of the vernier caliper as shown in the figures below?

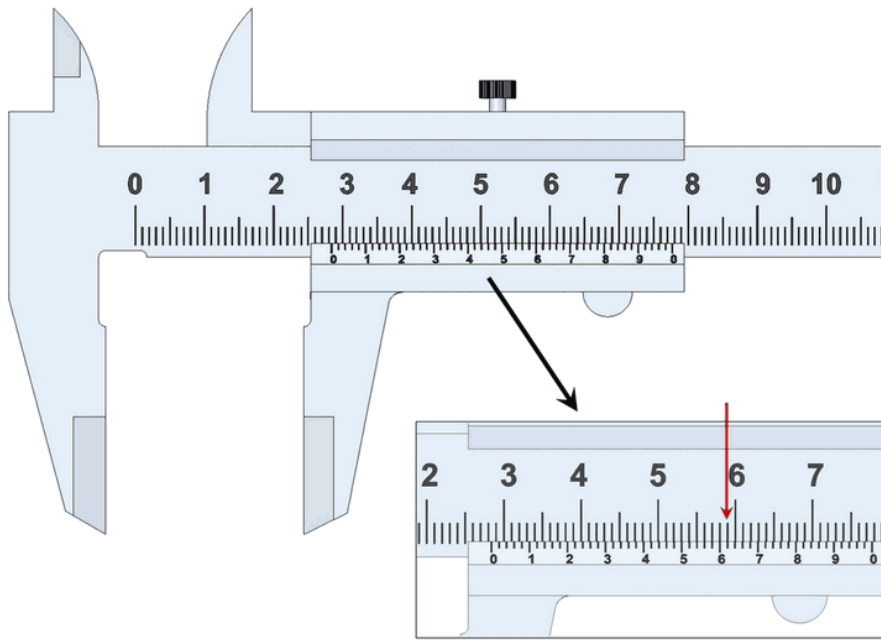

SOLUTION:

Reading of the main scale = 2.8 cm

Reading of vernier scale = 6

Reading of vernier scale x L.C of vernier caliper = $6 \times 0.01 = 0.06$ cm

We get the reading of the micrometer screw gauge = $2.8 + 0.06 = 2.86$ cm

Reading of vernier caliper = 2.86 cm

IMRAN HASHM

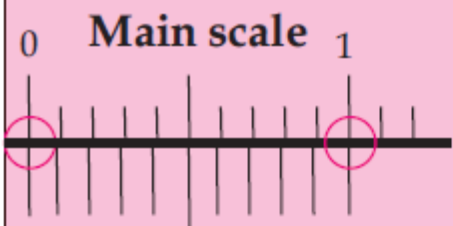
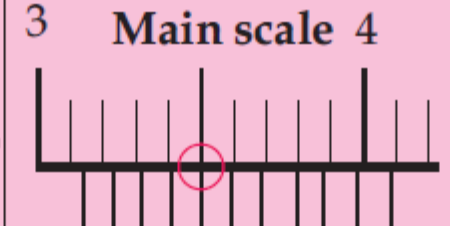
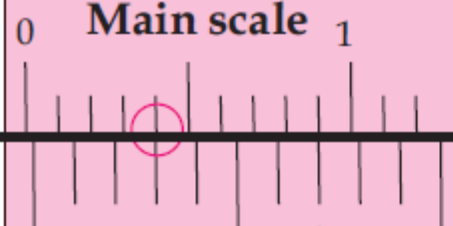
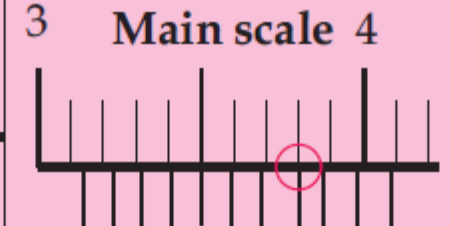
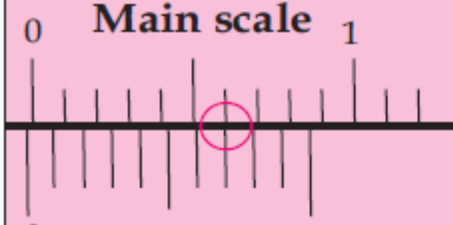
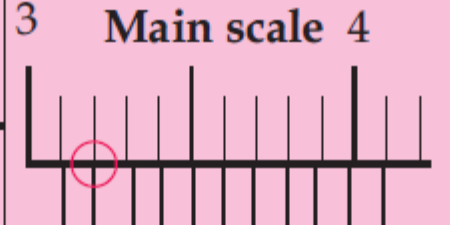
CHECKING FOR ZERO ERROR	OBSERVED READING	CORRECTED READING
 <p>Main scale 0 1</p> <p>Vernier scale 0 10</p> <p>Two zero marks coincide No Zero error.</p>	 <p>Main scale 3 4</p> <p>Vernier scale 0 10</p> <p>Reading=3.14cm</p>	<p>3.14cm (No zero error No correction required)</p>
 <p>Main scale 0 1</p> <p>Vernier scale 0 10</p> <p>zero mark on vernier scale is slightly to the right Zero error is 0.03</p>	 <p>Main scale 3 4</p> <p>Vernier scale 0 10</p> <p>Reading=3.17cm</p>	<p>3.17cm- (+0.03)=3.14cm (The positive zero error is subtracted from reading)</p>
 <p>Main scale 0 1</p> <p>Vernier scale 0 10</p> <p>Zero mark on vernier scale is slightly to the left. zero error of -0.07</p>	 <p>Main scale 3 4</p> <p>Vernier scale 0 10</p> <p>Reading=3.11cm</p>	<p>3.11cm -(-0.07) =3.18cm (Negative zero error is added to the reading)</p>

MICROMETER SCREW GAUGE

It is used to measure the diameter of a sphere

It consists of a U-shaped metallic frame whose one end is fixed, while a screw passes through the other end. The screw has a moveable end.

A millimeter scale is graduated on the fixed nut of the screw. A cap is provided at the end of the screw and it can be rotated to move the screw forward or backward.

On the edge of the cap, a circular scale is provided, this circular scale is marked with 100 or 50 divisions.



WORKED EXAMPLE

Q-1 What are the readings of the reading of the micrometer meter screw gauges as shown in the figures below?

SOLUTION:

Reading of the main scale = 22.0 mm

Reading of circular scale = 33

Reading of circular scale x L.C of screw gauge = $33 \times 0.01 = 0.33$ mm

We get the reading of the micrometer screw gauge = $2.0 + 0.33 = 22.33$ mm

Reading of screw gauge = 22.33 mm

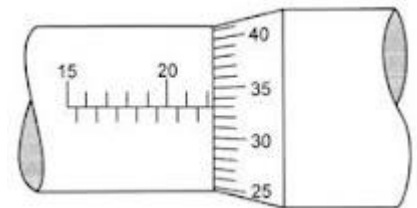

SOLUTION:

Reading of the main scale = 3.25 mm

Reading of circular scale = 13

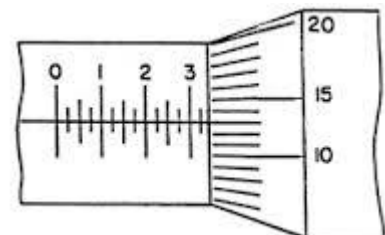

Reading of circular scale x L.C of screw gauge = $13 \times 0.01 = 0.13 \text{ mm}$

We get the reading of the micrometer screw gauge. = $3.25 + 0.13$

= 3.38 mm

Reading of the micrometer meter screw gauge = 3.38 mm

IMRAN HASHMI

Reading A Micrometer Screw Gauge

Step 1

Turn the thimble until the anvil and the spindle gently grip the object. Then turn the ratchet until it starts to click.

Step 2

Take the main scale reading at the edge of the thimble.

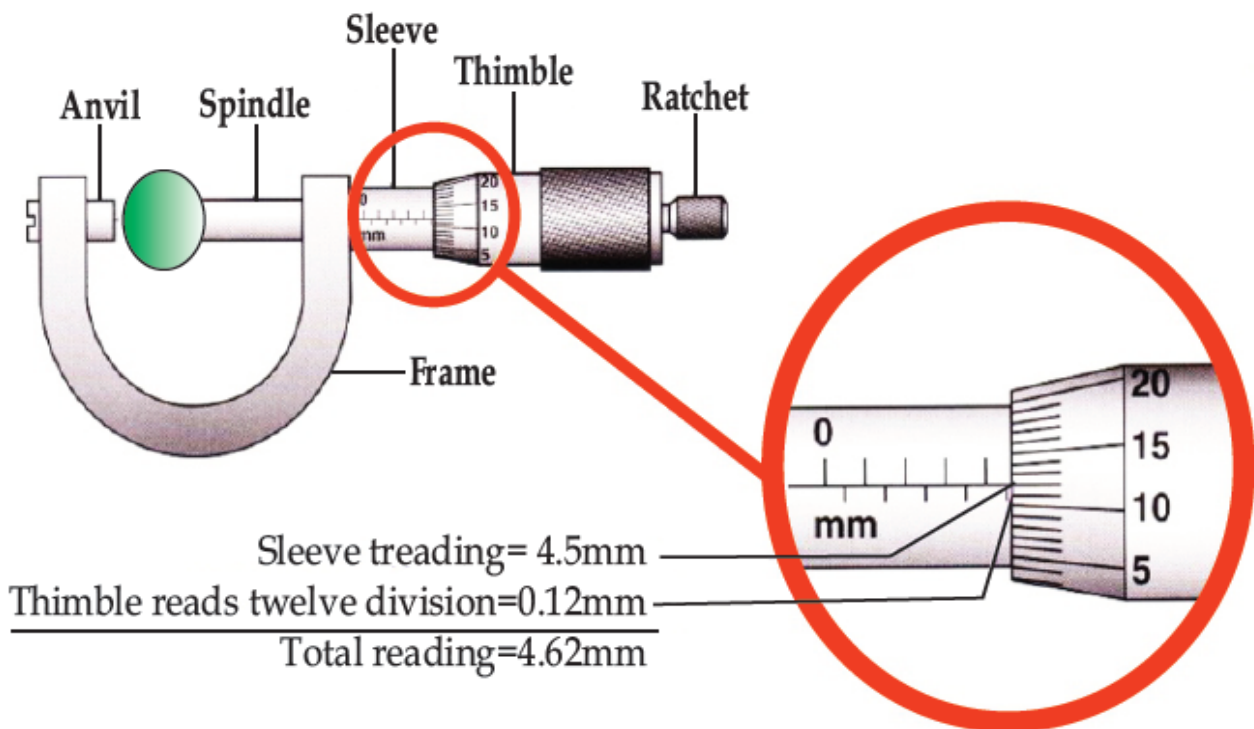

Step 3

Take the thimble scale reading opposite the datum line of the main scale. Multiply this reading with least count i.e., 0.01mm

Step 4

Now add main scale reading to thimble reading. This will be the diameter of the object.

ZERO ERROR

If the zero of circular scale does not coincide with the reference line of main scale then it is known as Zero Error.

There are two types of zero error.

1. POSITIVE ZERO ERROR

If the zero of the circular scale is below the reference line of the main scale, then this Error is called Positive Zero Error.

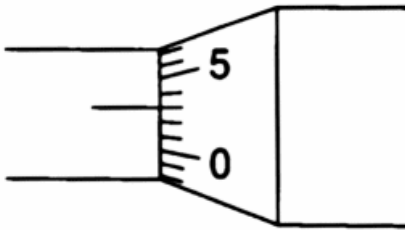

To calculate this Error, check which division of circular scale (E) exactly coincides with the reference line, then,

$$\text{Zero Error (Z.E)} = E \times \text{L.C}$$

$$\text{Zero Error (Z.E)} = 3 \times 0.001 = 0.003$$

2. NEGATIVE ZERO ERROR

If the zero of the circular scale is above the reference line of main, then this Error is called a Negative Zero Error.

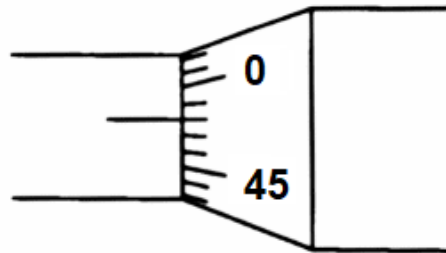

To calculate this Error, check which division of circular scale (E) exactly coincides with the reference line, then,

$$\text{Zero Error (Z.E)} = (E - 50) \times \text{L.C}$$

$$\text{Zero Error (Z.E)} = (48 - 50) \times 0.001$$

$$\text{Zero Error (Z.E)} = -2 \times 0.001 = -0.002$$

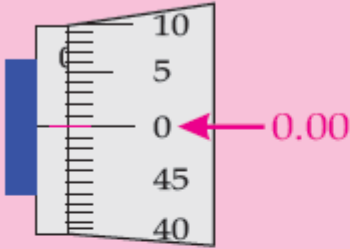
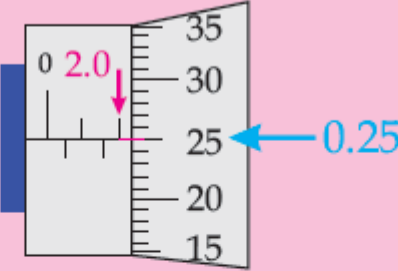
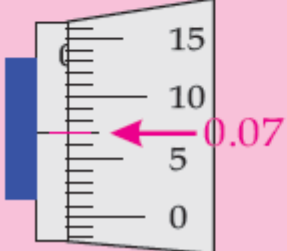
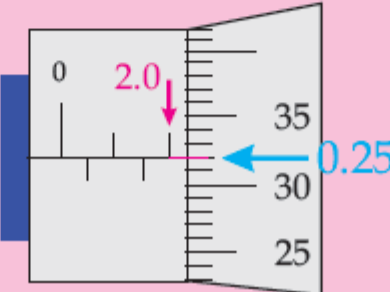
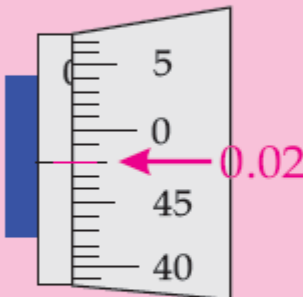
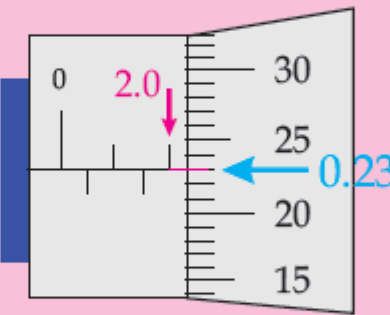
Checking For Zero Error	Observed reading	Corrected Reading
 <p>Zero mark on thimble scale coincides with the datum line on the main scale and reading on the main scale is zero. No zero error</p>	 <p>Reading = $2.0 + 0.25$ = 2.25mm</p>	<p>2.25mm No zero error No Correction is required</p>
 <p>Zero on datum line can be seen. Positive Zero Error Reading = +0.07 mm (Count from Zero.)</p>	 <p>Reading = $2.0 + 0.32$ = 2.32mm</p>	<p>$2.32 - (+0.07)$ = 2.25mm</p>
 <p>Zero mark on datum line cannot be seen negative zero error Reading = -0.02mm (count down from 0)</p>	 <p>Reading = $2.0 + 0.23$ = 2.23mm</p>	<p>$2.23 - (-0.02)$ = 2.25mm</p>

THE STANDARD OF MASS

The kilogram is the SI unit of mass and is equal to the mass of the international prototype of the kilogram.

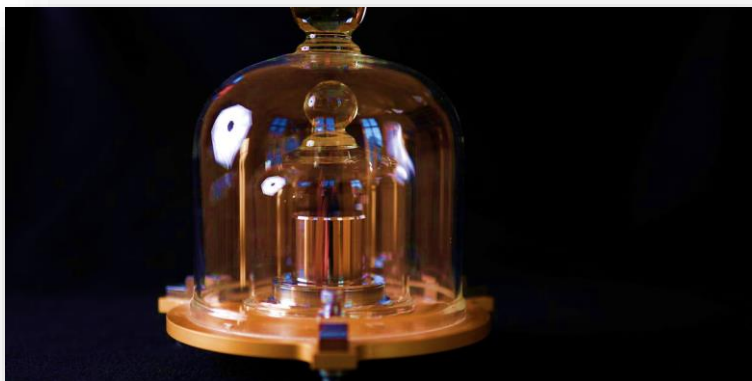

KILOGRAM

The mass of a cylinder of specific dimension of platinum – iridium alloy kept in the International Bureau of weight and Measures near Paris is taken to be the standard one kilogram.

A few of its submultiples are give as below:

$$1\text{kg} = 1000\text{ g} = 10^3\text{g}$$

$$1\text{g} = 1000\text{ mg} = 10^3\text{ mg}$$

THE PHYSICAL BALANCE

The Physical balance is an instrument used for the measurement of mass. It is mostly used in the laboratory. It works on the principle of moments. It consists of a light and rigid beam of brass, a metallic pillar, a wooden base, two pans, a metallic pointer, and an ivory scale (Fig). The plumb line indicates whether the balance is horizontal. In ideal conditions, the plumb line is aligned with the end of the knob fixed with the pillar. When the beam is horizontal the pointer remains on zero mark on the ivory scale.

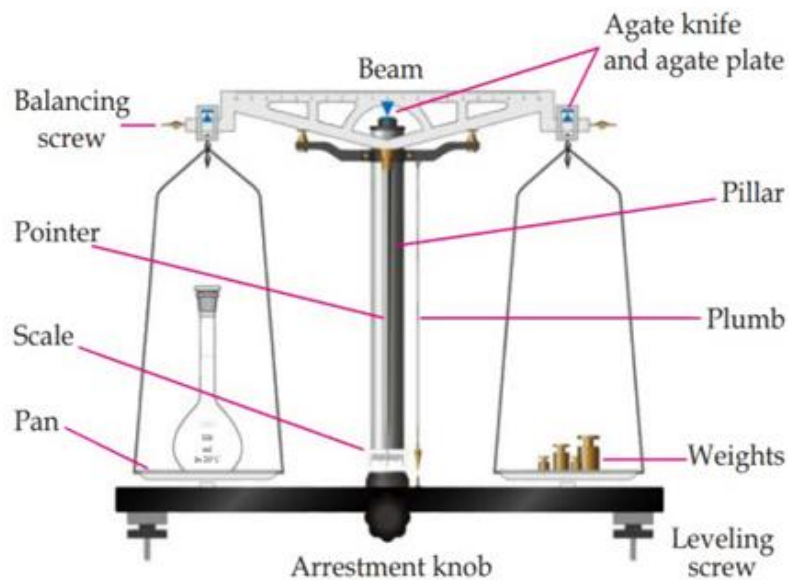

THE ELECTRONIC BALANCE

The digital mass meter is an electronic instrument configured with integrated circuits and, it works on the principle of balancing the forces. The device is turned on and set to zero, then the object is placed on the plate. The reading on the screen gives the mass of the object.



THE STANDARD OF TIME

In 1967, the second was redefined to take advantage of the high precision attainable in a device known as an atomic clock (Fig), which uses the characteristic frequency of the cesium-133 atom as the "reference clock".

SECOND

The second is defined in terms of period of vibration of a certain atom (cesium – 133 – Cs – 133). One second is 9, 192, 631, and 770 periods of vibrations of Cs – 133. This unit of time is ascertained through the cesium atomic clock. One such clock is at the National Bureau of Standard, Washington, U.S.A.

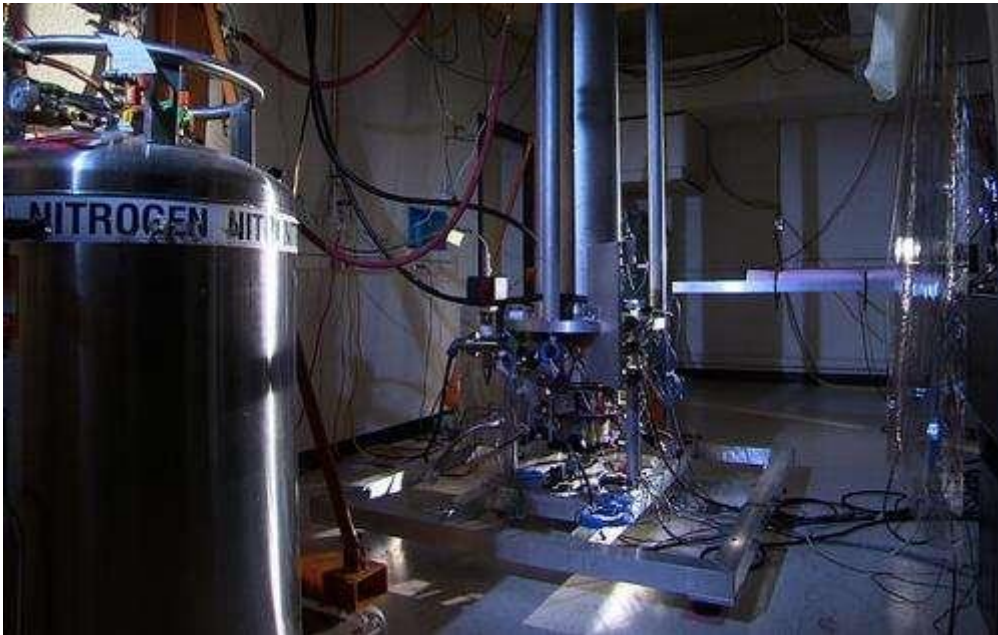

its related units are,

$$1 \text{ hr} = 60 \text{ min}$$

$$1 \text{ min} = 60 \text{ sec}$$

$$1 \text{ hr} = 60 \times 60 = 3600 \text{ sec.}$$

STOP WATCH

A stopwatch is used to measure the time interval between two events. There are two types of stopwatches: Mechanical stopwatches and Digital stopwatches.



PREFIXES FOR SI UNITS

Because the base SI units are sometimes too big or too small for use in measurement, prefixes are used with them to produce smaller or bigger units, which are convenient to work with (prefix is a word used before a unit name).

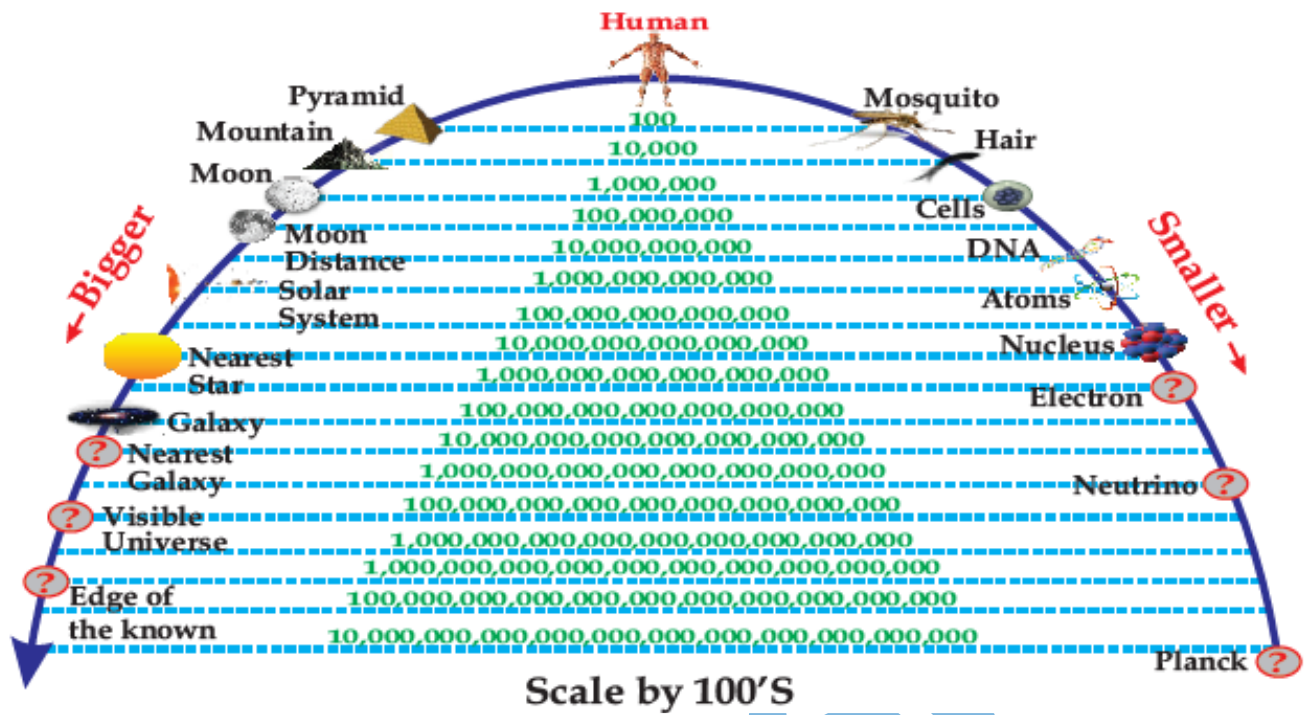

some of the prefixes used with SI units are given below.

Value	Prefix	Symbol
10^{24}	yotta	Y
10^{21}	Zetta	Z
10^{18}	exa-	E
10^{15}	peta-	P
10^{12}	tera-	T
10^9	giga-	G
10^6	mega-	M
10^3	kilo-	K
10^2	hecto-	h
10^1	deca-	da

10⁻¹	deci-	d
10⁻²	centi-	c
10⁻³	milli-	m
10⁻⁶	Micro	μ
10⁻⁹	nano-	n
10⁻¹²	pico-	p
10⁻¹⁵	femto-	f
10⁻¹⁸	atto-	a
10⁻²¹	zepto	z
10⁻²⁴	yocto	y

IMRAN HASHTAMI

DENSITY AND VOLUME

MEASURING THE VOLUME

For density to be measured or calculated we first need to find the volume of substances. Most solid geometrical shapes have formulae for their volume which is obtained through different parameters such as radius, height, depth, width, base, and length, but for irregular objects, liquids, and gases this approach is unusual. The volume of liquids can be measured with the help of Cylinders, and Beakers.

1. VOLUME OF LIQUID

A volume of about a liter or so can be measured using a measuring cylinder. When the liquid is poured into the cylinder the level on scale gives the volume. Most measuring cylinders have scales marked in milliliters (ml) or cubic centimeters (cm³).

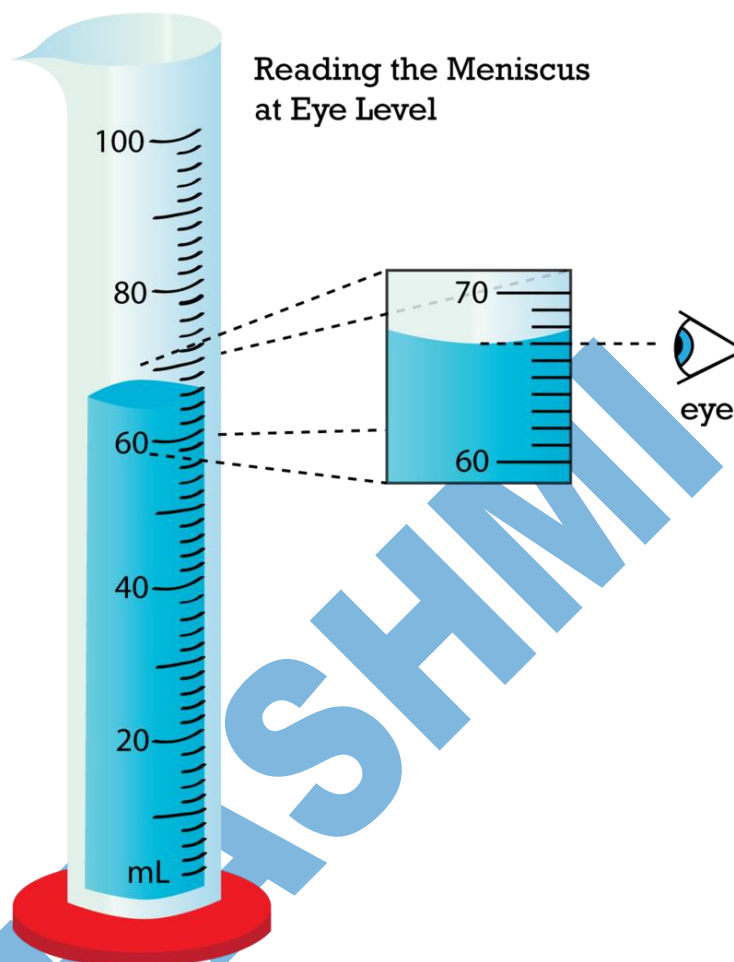

2. REGULAR SOLID

If an object has a regular shape its volume can be calculated



$$\text{Volume block} = \text{length} \times \text{width} \times \text{height}$$

$$\text{Volume of a sphere} = \frac{4}{3} \pi r^3$$

WORKED EXAMPLE

Q- Find the volume of a sphere of radius 9 cm

SOLUTIONS

$$V = \frac{4}{3} \pi r^3$$

$$V = \frac{4}{3} \pi (9)^3$$

$$V = 3053.6 \text{ cm}^3$$

THE VOLUME OF AN IRREGULAR-SHAPED OBJECT

The volume of an irregular-shaped object is measured by the amount of liquid that it displaces. First, determine the volume of water in a cylinder before the object is immersed in it. Read the new volume when the object is immersed. The difference between the two readings gives the volume of the irregular shaped object.

$$\text{Volume of the object} = V_2 - V_1$$

WORKED EXAMPLE

$$\text{Volume of the object} = V_2 - V_1$$

$$\text{Volume of the object} = 40 - 30$$

$$\text{Volume of the object} = 10$$

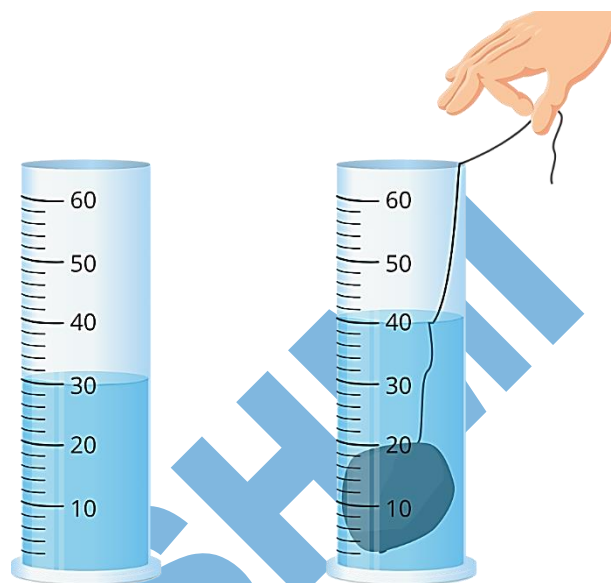

DENSITY

A uniform composition substance's density is defined as its mass per unit volume.

FORMULA

In symbol form,

The symbol ρ (rho, Greek letter r) is used to represent density,

$$\rho = \frac{m}{V}$$

Where,

ρ = density of the substance in g cm^{-3}

m = mass of the substance in g

V = volume of the substance in cm^{-3}

UNIT OF DENSITY

SI unit of density is the kilogram per cubic meter (Kg m^{-3}). The gram per cubic centimeter (g cm^{-3}) is a more commonly used.

$$1 \text{ g cm}^{-3} = 1000 \text{ Kg m}^{-3}$$

WORKED EXAMPLE

Q: You have a rock with a volume of 15cm^3 and a mass of 45 g. What is its density?

SOLUTIONS

$$\rho = \frac{m}{V}$$

$$\rho = \frac{45}{15}$$

$$\rho = 3 \text{ g/cm}^3$$

SIGNIFICANT FIGURES

The number of accurately known digits and the first doubtful digit(called least significant) are known as significant figures or significant digits.

RULES OF DETERMINATION SIGNIFICANT FIGURES

1. **ALL non-zero numbers (1,2,3,4,5,6,7,8,9) are ALWAYS significant**

EXAMPLE

- | | |
|------------------------------------|--------------------------------------|
| (i) 3423
4- significant figure | (ii) 457435
6 -significant figure |
| (iii) 587
3- significant figure | (iv) 58
2- significant figure |

2. **ALL zeroes between non-zero numbers are ALWAYS significant**

EXAMPLE

- | | |
|------------------------------------|---------------------------------------|
| (i) 3003
4- significant figure | (ii) 40.009
5 -significant figure |
| (iii) 507
3- significant figure | (iv) 5000097
3- significant figure |

3. Zeros locating the position of decimal in numbers of magnitude less than one are not significant

EXAMPLE

- | | |
|--|---|
| (i) 0.0063
2- significant figure | (ii) 0.009
1 -significant figure |
| (iii) 0.0000307
3- significant figure | (iv) 0.0009078
4 -significant figure |

4. Final zeros to the right of the decimal point are significant.

EXAMPLE

- | | |
|--|--|
| (i) 7.0500
5- significant figure | (ii) 0.00900
3 -significant figure |
| (iii) 9.00300
6- significant figure | (iv) 0.090200
5- significant figure |

5. Zeros at the end of the numbers greater than one may are may not be significant

EXAMPLE

- | | |
|----------------------------------|--------------------------------------|
| (i) 700
1- significant figure | (ii) 980000
2- significant figure |
|----------------------------------|--------------------------------------|

6. For any value written in scientific notation as $A \times 10^x$, the number of significant figures is determined by applying the above rules only to the value of A.

EXAMPLE

- 4.5×10^3 has two significant figures
 4.50×10^{-9} has three significant figures
 4.500×10^{23} has four significant figures